

THIS DRAWING IS UNPUBLISHED. RELEASED FOR PUBLICATION  
 © COPYRIGHT BY TYCO ELECTRONICS CORPORATION. ALL RIGHTS RESERVED.

LOC	DIST	REVISIONS					
AF	50	P	LTR	DESCRIPTION	DATE	DWN	APVD
			N2	REVISED PER ECR-08-014126	12JUN08	HMR	GP

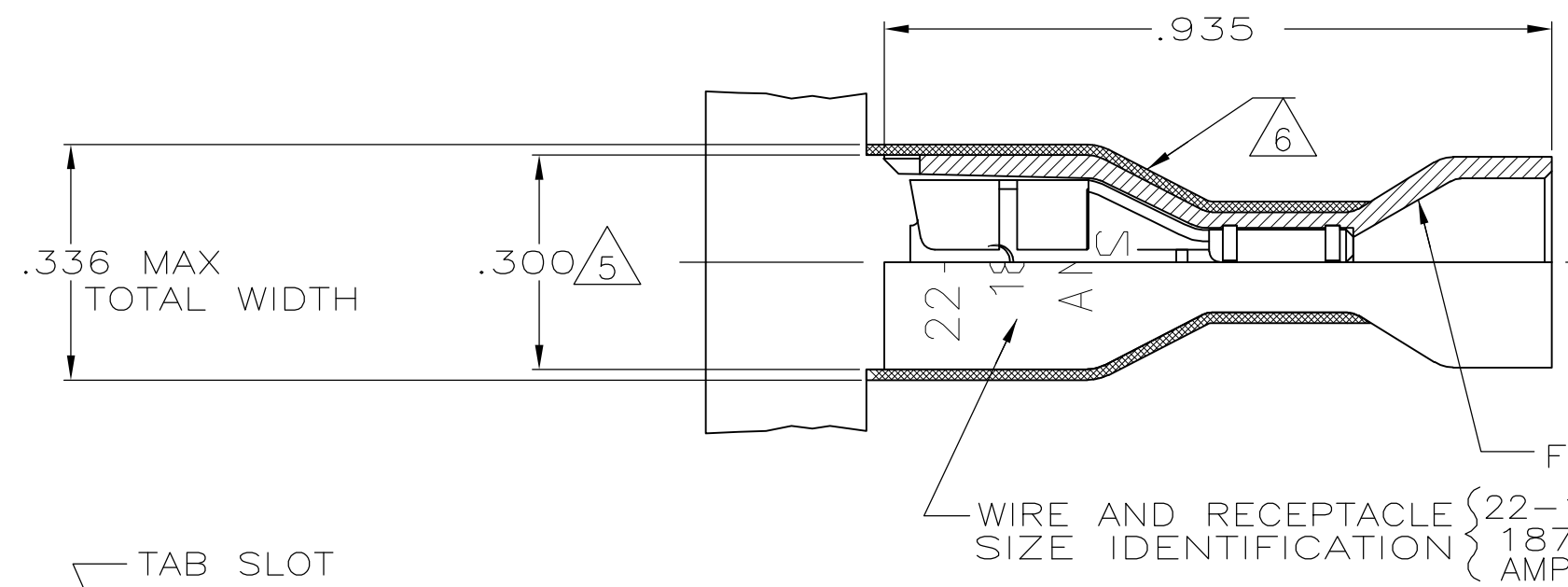

- 1 MATES WITH .020±.001X.187 TAB
- 2 WIRE STRIP LENGTH .281
- 3 INSULATION SIZE .230 MAX DIA
- 4 CONTINUOUS STRIP ON REELS
- △5 DIMENSION DOES NOT INCLUDE TRIM BURR
- △6 .015 MAX CARRIER TRIM BURR PER SIDE IS ALLOWABLE IN THE SHADED AREA
- △7 PRE-PRODUCTION-FASR REQUIRED PER TAR

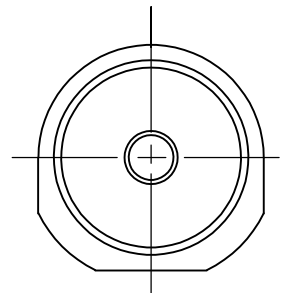
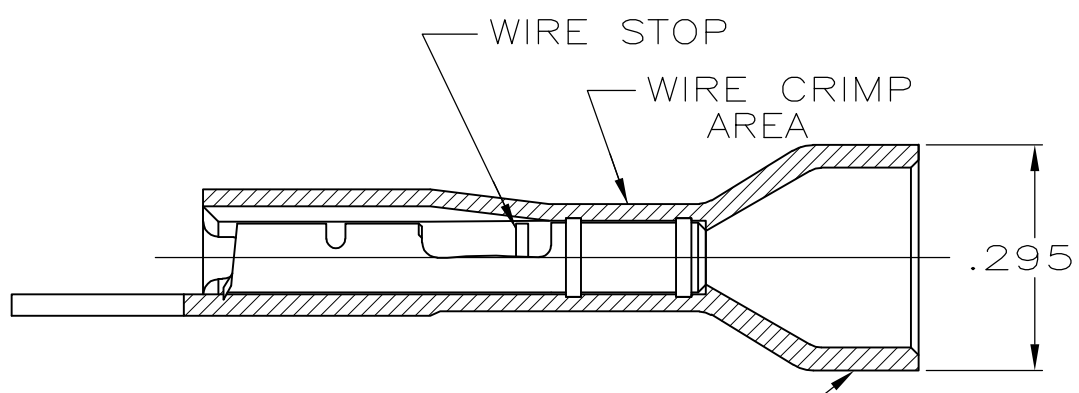
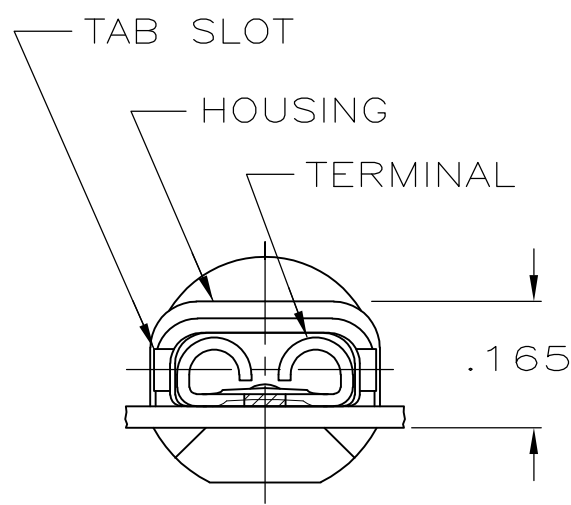

	STANDARD	HOUSING: NYLON, COLOR-BLACK RECEPTACLE: #3 HARD BRASS TIN PL .000080 MIN THK	△7 9-520261-2
OBSOLETE	BULK	HOUSING: NYLON, COLOR-RED TRANSLUCENT RECEPTACLE: #3 HARD BRASS TIN PL .000080 MIN THK	5-520261-2
	STANDARD	RECEPTACLE: #3 HARD BRASS TIN PL .000080 MIN THK	2-520261-2
	PACKAGING	MATERIAL & FINISH	PART NO.

THIS DRAWING IS A CONTROLLED DOCUMENT.		DWN P FORTNEY 11/4/88	Tyco Electronics Corporation Harrisburg, PA 17105-3608	
DIMENSIONS: INCHES		CHK MS FEHER 11/7/88		
TOLERANCES UNLESS OTHERWISE SPECIFIED:		APVD T SHUTTER 11/7/88	NAME	
0 PLC ± - 1 PLC ± - 2 PLC ± - 3 PLC ± .015 4 PLC ± - ANGLES ± -		PRODUCT SPEC 108-2043	RECEPTACLE ASSY, ULTRA-FAST, .187 SERIES, 22-18 AWG	
MATERIAL SEE TABLE		FINISH SEE TABLE	APPLICATION SPEC 114-2123	RESTRICTED TO
		WEIGHT -	SIZE A3	CAGE CODE 00779
		CUSTOMER DRAWING	DRAWING NO C-520261	REV N2
		SCALE 4:1	SHEET 1 OF 1	